

THE INSTRUMENT

I. Introduction

TeachSpin's PS1-A is the first pulsed nuclear magnetic resonance spectrometer designed specifically for teaching. It provides physics, chemistry, biology, geology, and other science students with the hands-on apparatus with which they can learn the basic principles of pulsed NMR. It was developed by faculty with more than 60 years of accumulated research and teaching in the field of magnetic resonance. Its modular construction allows you to experiment with each part of the apparatus separately to understand its function as well as to make the appropriate interconnections between the modules. For its high field, high homogeneity permanent magnet, the PS1-A uses new high-energy magnetic materials. Solid-state technology is employed in the digitally synthesized oscillator which creates a stable frequency source. Unique switching and power amplifier circuits create coherent and stable pulsed radio frequency magnetic fields. The spectrometer uses a crossed-coil sample probe with a separate transmitter and receives coil which are orthogonal. This design completely separates the transmitter and receiver functions and makes their analysis easy to understand, measure and test.

PS1-A has a state-of-the-art high sensitivity, high gain receiver with a linear detector that permits accurate measurement of the signal amplitude even at low levels. The instrument is not only easy to use, it is easy to understand since each module has its own clearly defined function in the spectrometer and is accessible to individual examination. The spectrometer is complete, requiring only your samples and an oscilloscope to record the data. The Hewlett Packard 54600A digital storage scope is highly recommended for this purpose, since it is well engineered, easy to operate, reasonably priced, and will greatly simplify data taking and analysis. However, a standard analog scope with a bandwidth of at least 20 MHz will also adequately serve to record the pulsed signals. The spectrometer is capable of measuring a wide variety of samples which have appreciable proton concentrations. The only restriction is that the sample's $T_2 \geq 5 \times 10^{-5}$ s which includes most liquids and some solid condensed matter.

II. Block Diagram of Instrument

Figure 1.2 is a simplified block diagram of the apparatus. The diagram does not show all the functions of each module, but it does represent the most important functions of each modular component of the spectrometer.

The pulse programmer creates the pulse stream that gates the synthesized oscillator into radio frequency pulse bursts, as well as triggering the oscilloscope on the appropriate pulse. The rf pulse bursts are amplified and sent to the transmitter

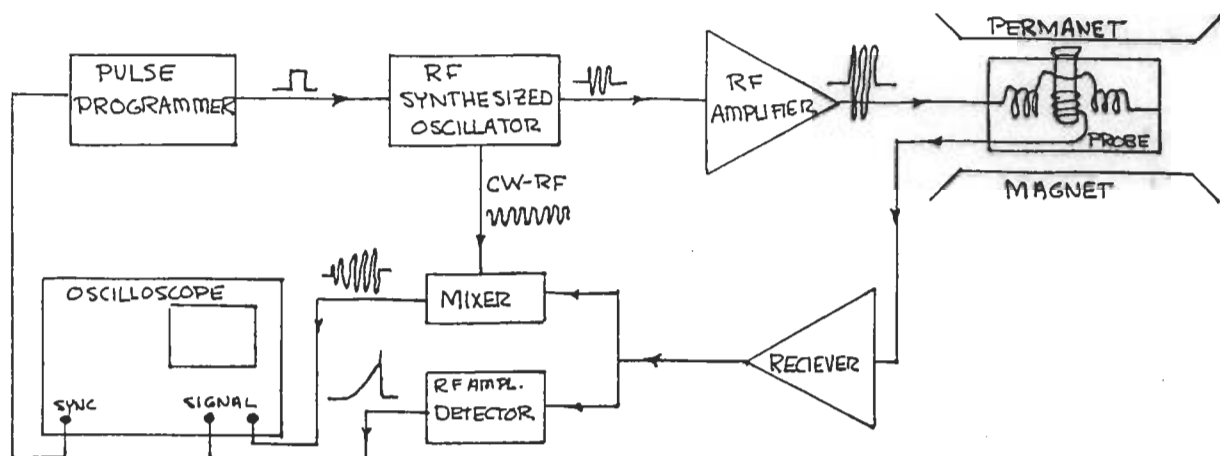

Fig. 1.2

coils in the sample probe. The rf current bursts in these coil produce a homogeneous 12 gauss rotating magnetic field at the sample. These are the time-dependent B_1 fields that produce the precession of the magnetization, referred to as the 90° or 180° pulses. The transmitter coils are wound in a Helmholtz configuration to optimize rf magnetic field homogeneity.

Nuclear magnetization precession in the direction transverse to the applied constant magnetic field (the so called x-y plane) induces an EMF in the receive coil, which is then amplified by the receiver circuitry. This amplified radio frequency (15 MHz) signal can be detected (demodulated) by two separate and different detectors. The rf **amplitude** detector rectified the signal and has an output proportioned to the peak amplitude of the rf precessional signal. **This is the detector that you will use to record both the free induction decays and the spin echoes signals.**

The other detector is a **mixer**, which effectively multiplies the precession signal from the sample magnetization with the master oscillator. Its output frequency is proportional to the difference between the two frequencies. **This mixer is essential for determining the proper frequency of the oscillator.** The magnet and the nuclear magnetic moment of the protons uniquely determine the precessional frequency of the nuclear magnetization. The oscillator is tuned to this precession frequency when a zero-beat output signal of the mixers obtained. A dual channel scope allows simultaneous observations of the signals from both detectors, The field of the permanent magnet is temperature dependent so periodic adjustments in the frequency are necessary to keep the spectrometer on resonance.

B. Case with Power Supply

The case for the modules has a fused and switched power entry unit located on the back right side. The unit uses 2 amp slow blow fuses. A spare set of fuses is stored inside the fuse case. The spectrometer case has a linear power supply enclosed. It has slots for five modules, which connect to the power supply through a back plane of electrical connectors. The modules should be located as follows:

Fig. 2.2

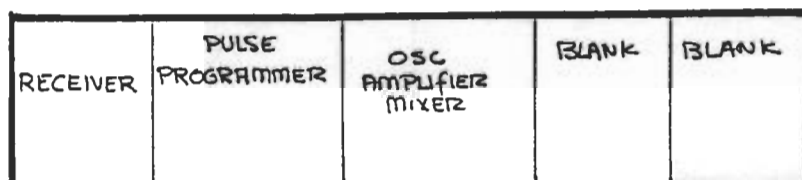

The empty slots will accept future modules to upgrade and enhance this spectrometer. Call us to discuss these additional units. We expect them to be available by January 1995.

C. Pulse Programmer PP-101

The pulse programmer is a complete, self contained, pulse generator which creates the pulse sequences used in all the experiments. The pulses can be varied in width (pulse duration), spacing, number, and repetition time. Pulses are about 4 volt positive pulses with a rise time of about 15 ns. The controls and connectors are described below and pictured in Fig. 3.2

A-width: width of A pulse 1-30 μ s continuously variable

B-width: width of B pulse 1-30 μ s continuously variable

Delay time: 1) with number of B pulses set at 1, this is the time delay between the A and B pulses.

2) with number of B pulses set at 2 or greater, this is the time between A and the first B pulse and one half of the time between the first B pulse and the second B pulse.

3) delay range can be varied from:
10 μ s (which appears as 0.01x10⁰ ms)
to
9.99 s (which appears as 9.99 x 10⁹ ms)

Accuracy: 1 pt in 10⁶ on all delay times.

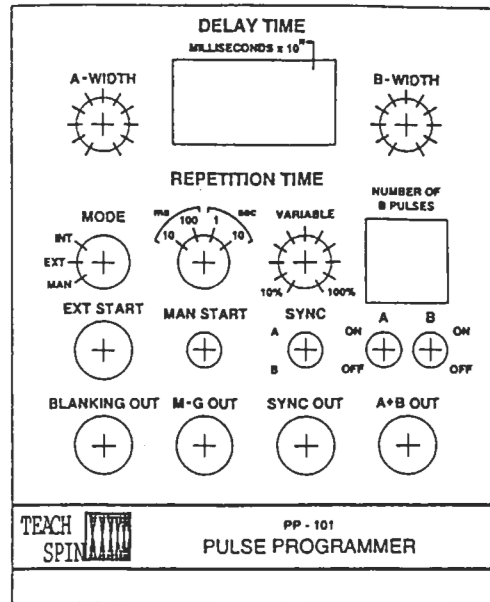

Fig. 3.2 Front panel of pulse programmer

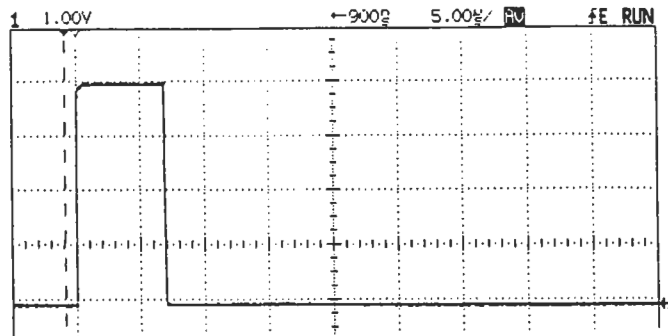

Fig. 4.2 A single A pulse about 7 μs duration.

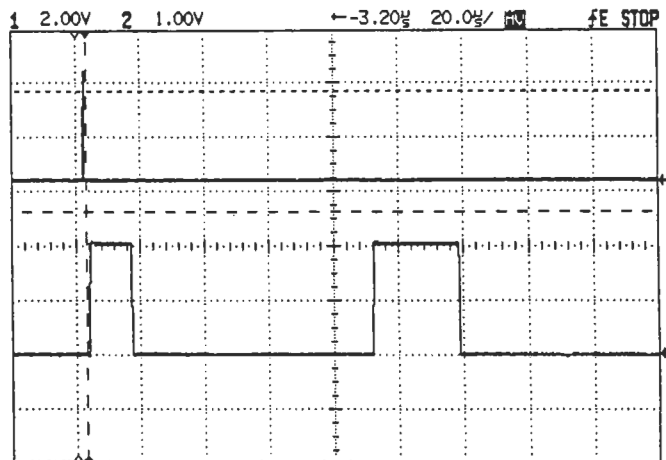

Fig. 5.2 A two pulse sequence where the B pulse (second one on the right) has a 28 μs duration. The upper trace shows the sync pulse that was used to trigger the oscilloscope on the A pulse.

Mode: This switch selects the signal that starts the pulse sequence. There are three options

Int (Internal): The pulse stream is repeated with a repetition time selected by the two controls at the right of the mode switch.

Ext (External): The pulse stream is repeated at the rising edge of a TTL pulse.

Man (Manual): The pulse stream is repeated every time the manual start button is pushed. This allows the experimenter to choose arbitrarily long repetition times for the experiment.

Repetition Time: four position 10ms, 100 ms, 1s
10 s, variable 10-100% on any of the four position.
Thus for 100 ms and 50%, the repetition time is 50 ms.
The range of repetition times is 10 ms 10% or 1 ms to 10 s
100% or 10 s.

Number of B Pulses: This sets the number of B pulses from 0 to 99

Ext-Start: Rising edge of a TTL pulses will start a single pulse stream.

Man-Start: Manual start button which starts pulse stream on manual mode.

Sync Switch: This switch allows the experimenter to choose which pulse, A or B, will be in time coincides with the output sync pulse. In Fig. 5.2, the upper trace shows the sync pulse occurring at the beginning of the A pulse.

A-switch: turns on or off the A pulse output

B-switch: turns on or off the B pulse output

Blanking out: A blanking pulse used to block the receiver during the rf pulse and thus to improve the receiver recovery time.

M-G out: Meiboom-Gill phase shift pulse, connected to the oscillator, to provide a 90° phase shift after the A pulse.

Sync out: A fast rising positive 4 volt pulse of 200 ns duration used to trigger an oscilloscope or other data recording instrument. Fig. 6.2, top trace show the sync pulse coincident with the beginning of the B pulse (lower trace).

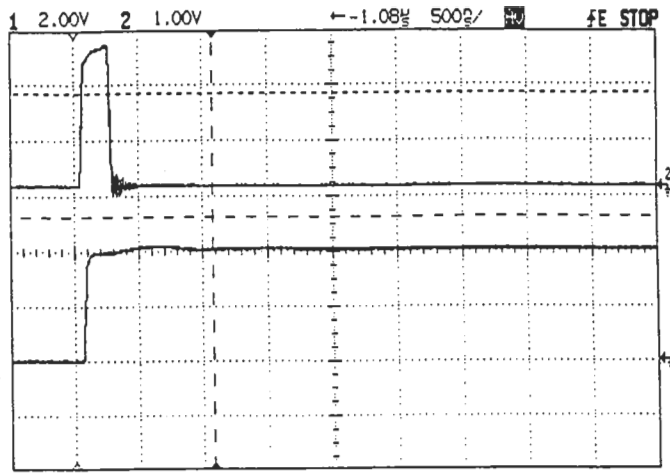

Fig.6.2

A & B OUT: 4 volt positive A & B pulses, shown in Fig.5.2.

D. 15 MHz OSC/AMP/MIXER:

There are three separate functioning units inside this module. A tunable 15 MHz oscillator, an rf power amplifier, and a mixer. The oscillator is digitally synthesized and locked to a crystal oscillator so that its stability is better than 1pt in 10^6 over 30 minutes. The frequency in MHz is displayed on a seven digit LED readout at the top center of the instrument (See Fig. 7.2). This radio frequency signal can be extracted as a continuous signal (CW-RF out, switch on) or as rf pulse burst in to the transmitter coil inside the sample probe.

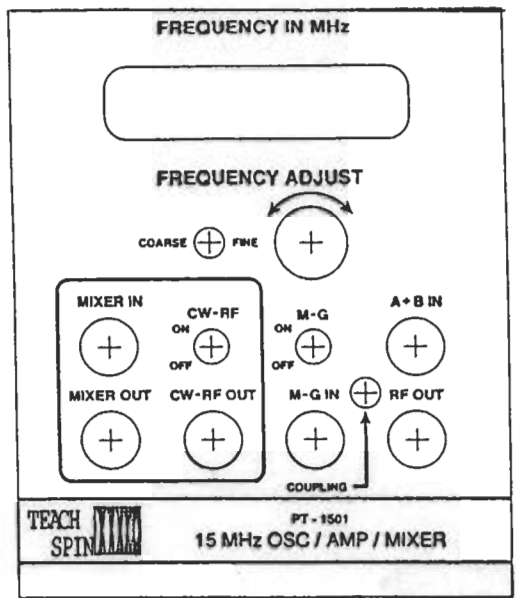

Fig.7.2

The second unit is the **power amplifier**. It amplifies the pulse bursts to produce 12 Gauss rotating radio frequency magnetic fields incident on the sample. It has a peak power output of about 150 watts.

The third unit is the **mixer**. It is a nonlinear device that effectively multiplies the CW rf signal from the oscillator with the rf signals from the precessing nuclear magnetization. The frequency output of the mixer is proportional to the difference frequencies between the two rf signals. If the oscillator is

properly tuned to the resonance, the signal output of the mixer should show no "beats", but if the two rf signals have different frequencies a beat structure will be superimposed on the signal. The beat structure is clearly evident on the upper trace of the signals from a two pulse free induction spin echo signal, shown in Fig. 8.2. The mixer output and the detector output from the receiver module may have identical shape. It is essential, however, to tune the oscillator so as to make these two signals as close as possible and obtain a zero-beat condition. That is the only way you can be sure that the spectrometer is tuned to resonance for the magnetic field imposed.

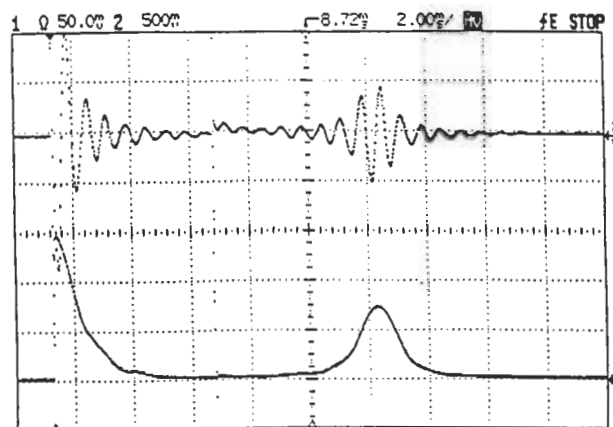

Fig. 8.2

IMPORTANT: DO NOT OPERATE THE POWER AMPLIFIER WITHOUT ATTACHING TNC CABLE FROM SAMPLE PROBE. DO NOT OPERATE THIS UNIT WITH PULSE DUTY CYCLES LARGER THAN 1%. DUTY CYCLES OVER 1% WILL CAUSE OVERHEATING OF THE OUTPUT POWER TRANSISTORS. SUCH OVERHEATING WILL AUTOMATICALLY SHUT DOWN THE AMPLIFIER AND SET OFF A BUZZER ALARM. IT IS NECESSARY TO TURN OFF THE ENTIRE UNIT TO RESET THE INSTRUMENT. POWER WILL AUTOMATICALLY BE SHUT OFF TO THE AMPLIFIER IN CASE OF OVERHEATING AND RESET ONLY AFTER THE INSTRUMENT HAS BEEN COMPLETELY SHUT OFF AT THE AC POWER ENTRY.

in **Frequency in MHz:** The LED displays the synthesized oscillator frequency megahertz (10^6 cycles/second).

Frequency Adjust: this knob changes the frequency of the oscillator. When the switch (at its left) is on **course** control, each "click" changes the frequency by 1,000 Hz, when it is switched to **fine**, each click changes the frequency 10 Hz. The smallest change in this digitally synthesized frequency is 10 Hz.

The Mixer (inside black outline)

Mixer In - rf input signal from receiver, 50 m V rms (max.)

Mixer Out - detected output, proportional to the difference between cw-rf and rf from precessing magnetization. Level, 2 v rms (max.)

bandwidth 500 kHz.

CW-RF switch: on-off switch for cw-rf output.

CW-RF OUT: continuous rf output from oscillator - 13dbm into 50Ω load.

M-G Switch: turns on phase shift of 90° between A and B pulse for multipulsed Meiboom-Gill pulse sequence.

A & B in: input for A & B pulses from pulsed programmer.

RF out: TNC connector output of amplifier to the transmitter coil inside sample probe. Radio frequency power bursts that rotate magnetization of the sample.

Coupling: This adjustment should only be made by the instructor using a small screwdriver. Adjusting the screw inside the module optimizes the power transfer to the transmitter coils in the sample probe. This adjustment has been made of the factory and should not need adjusting under ordinary operating conditions.

E. 15 MHz Receiver

This is a low noise, high gain, 15 MHz receiver designed to recover rapidly from an overload and to amplify the radio frequency induced *EMF* from the precessing magnetization. The input of the receiver is connected directly to a high Q coil wrapped around the sample vials inside the sample probe. The tiny induced voltage from the precessing spins is amplified and detected inside this module. The module provides both the amplified rf signal as well as detected signal. The rf signal can be examined directly on the oscilloscope. For example, Fig. 9.2

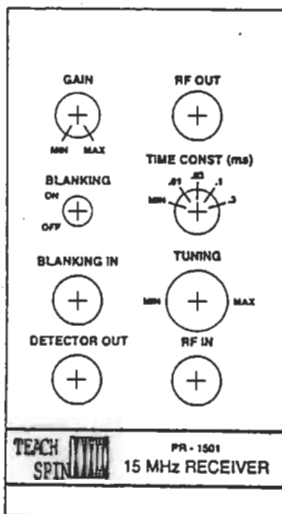
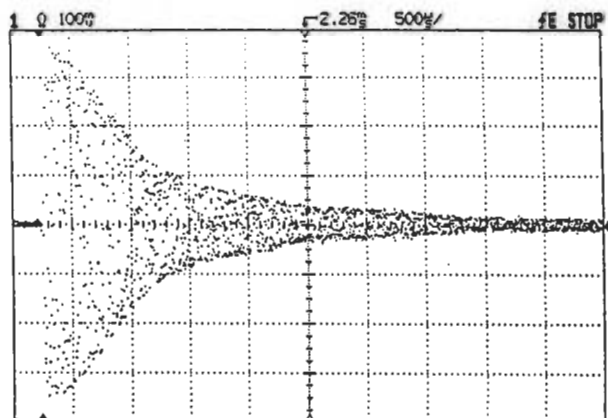

Fig.9.2



shows a free induction decay signal from precessing nuclear magnetization in mineral oil. This data was obtained on the HP 54600A digital oscilloscope. On this instrument, it is not possible to see the individual 15 MHz cycles, but with an analog scope, these cycles can be directly observed. Please note, these are *not* the beat cycles seen in the output of the mixer, but decaying 15 MHz oscillations of the free induction decay.

Gain: continuously variable, range 60 dB (typical)

RF out: amplified radio frequency signal from the precessing nuclear magnetization

Blanking: turns blanking pulse on or off

Blanking In: input from blanking pulse, to reduce overload to the receiver during the power rf pulses.

Time Constant: selection switch for RC time constant on the output of the amplitude detector. The longer the time constant, the less noise that appears with the signal. However, the time constant limits the response time of the detector and *may* distort the signal. The longest time constant should be compatible with the fastest part of the changing signal.

Tuning: rotates a variable air capacitor which tunes the first stage of the amplifier. It should be adjusted for maximum signal amplitude of the precessing magnetization.

Detector Out: the output of the amplitude detector to be connected to the vertical scope input.

RF In: To be connected to the receiver coil inside the sample probe. This directs the small signals to the first stage of the amplifier.

Fig. 10.2 shows a two pulse (90° - 180°) free induction decay - spin echo signal as observed from the rf output port (upper trace) and detector output port (lower trace) of the receiver. Again, it is not possible to observe the individual oscillation of the 15 MHz on this trace (with this time scale and the digital scope) but it is clear that the detector output rectifies the

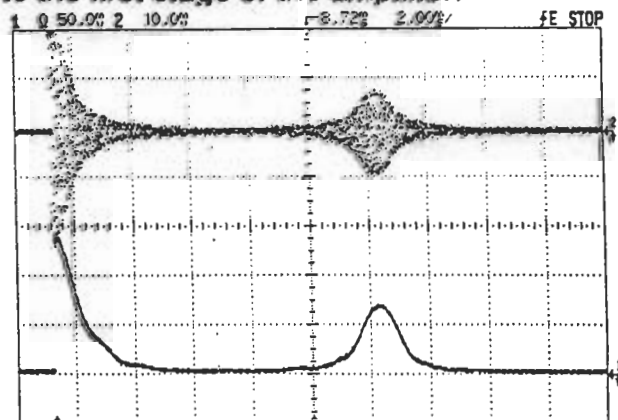

Fig.10.2

signal ("cuts" it in half) and passes only the envelope of the rf signal. It is also important to remember that the precession signal from spin system cannot be observed during the rf pulse from the oscillator /amplifier since these transmitter pulses induce voltages in the receiver coil on the order of 10 volts and the nuclear magnetization creates induced EMF 's of about $10\mu V$; a factor of 10^6 smaller!

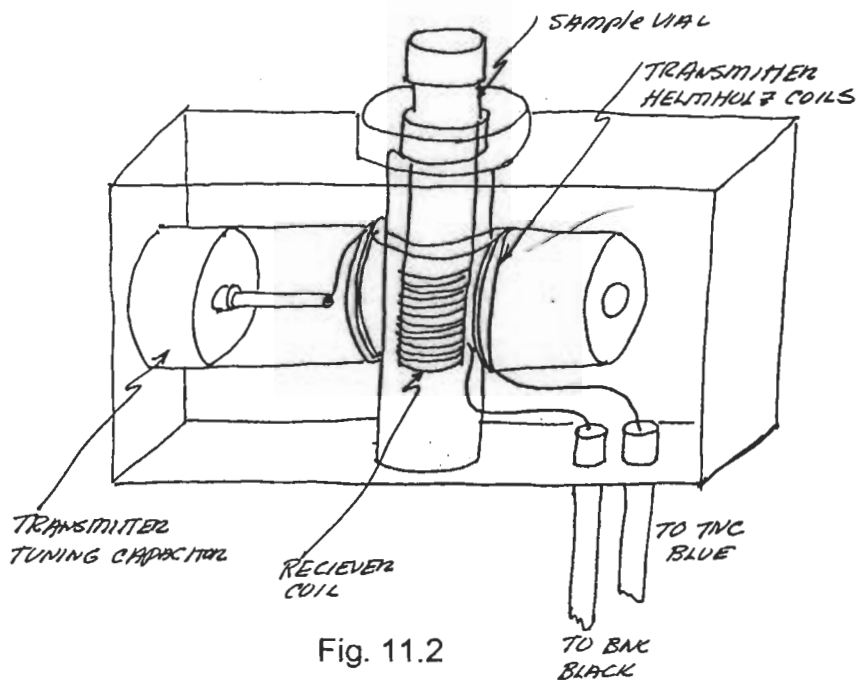

Fig. 11.2

Fig. 11.2 shows an artist sketch of the sample probe. The transmitter coil is wound in a Helmholtz coil configuration so that the axis is perpendicular to the constant magnetic field. The receiver pickup coil is wound in a solenoid configuration tightly around the sample vial. The coil's axis is also perpendicular to the magnetic field. The precessing magnetization induces an EMF in this coil which is subsequently amplified by the circuitry in the receiver. Both coaxial cables for the transmitter and receiver coils are permanently mounted in the sample probe and should not be removed. Caution should be exercised if the sample probe is opened since the wires inside are delicate and easily damaged. Care should be exercised that **no foreign objects, especially magnetic objects are dropped inside the sample probe.** They can seriously degrade or damage the performance of the spectrometer.

F. Linearity

~~Students should be aware of the nonlinearity inherent in the amplitude detector of the receiver. This nonlinearity can give rise to spurious measurements of both T_1 and T_2 , if the data is not correctly taken and analyzed.~~

Page 25a shows the amplitude detector's response curve with the obvious nonlinearity for DC output levels below 2.5 volts. This curve represents a typical receiver, but the exact curve for each receiver may vary by $\pm 5\%$. The students may use this data as a calibration curve for signals below 2.5 volts.

Alternatively the experiments can be arranged so that the signals used to measure the spin-spin or spin-lattice relaxation times are always larger than 2.5 volts. This method entails varying the uncalibrated gain control for the smaller signals. In this case, the student must calibrate the relative gain used for the weaker signals by some method. One way is to measure a signal over 2.5 volts on both the low and the higher gain settings.

Although T_1 and T_2 can be measured on one gain setting using signals larger than 2.5 volts at the output, it is a useful pedagogical exercise for the student to measure these quantities over a large range of signal strengths. This requires them to use one of the methods suggested above.

G. Auxiliary Components

1. PICKUP PROBE

A single loop of # 32 wire with a diameter of 6mm is used to measure the B_1 of the rotating rf field. This loop is encapsulated with epoxy inside a sample vial and attached to a short coaxial cable. The coaxial cable has a female BNC connector at the other end. To effectively eliminate the effects of the coaxial cable on the pickup signal from the transmitter pulse, a 50 ohm termination is attached at the pickup loop end as shown in the diagram. Since the single loop has a very low impedance, the signal at the oscilloscope is essentially the same as the signal into an open circuit. Note: the orientation of the pickup loop inside the sample holder is important, since the plane of the loop must be perpendicular to the rf field. (Faraday's Law!)

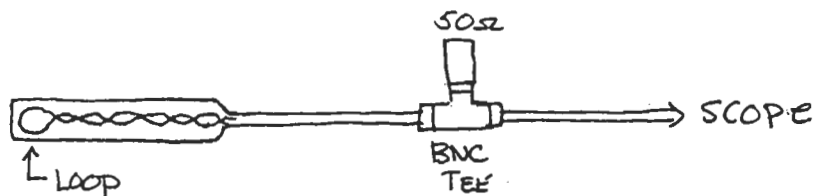

2. DUMMY SIGNAL COIL

A second single loop of # 32 wire in series with a 22k resistor is used to create a "dummy signal". This probe is also placed in the sample holder and located at the proper depth to produce the maximum signal. The loop is also connected to the terminating resistor to eliminate cable effects. This probe is attached to the cw output of the oscillator to create a signal which can be used to tune and calibrate the spectrometer. The connections are shown in the diagram.

